

A. M. BAILEY & J. O. COUCH.  
MACHINE FOR DRIVING SCREWS.

No. 43,384,

Patented July 5, 1864.

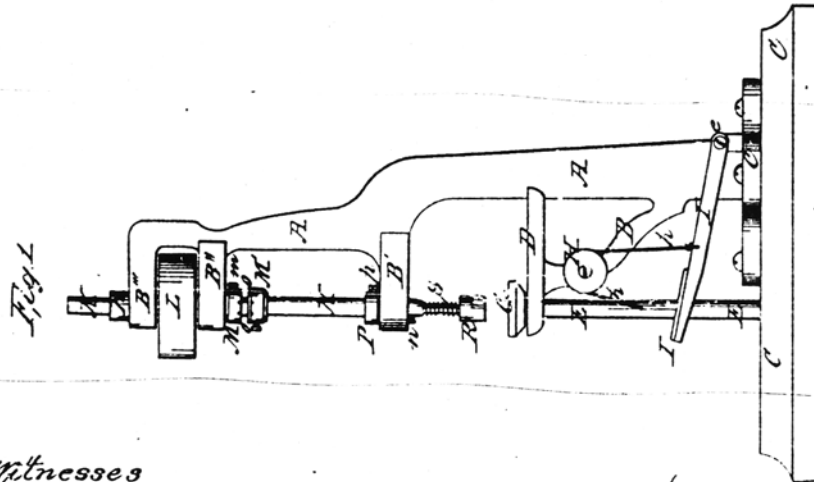
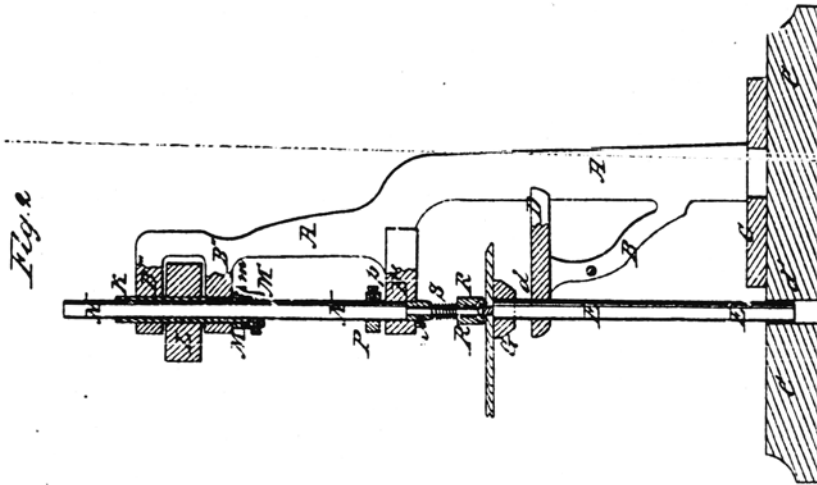

Witnesses  
*Carroll Eddy*  
*Jr. & Combs*

Inventor  
*Bailey & Couch*  
*by S. P. Potts*  
*their atty*

# UNITED STATES PATENT OFFICE.

ALFRED M. BAILEY AND JOHN O. COUCH, OF MIDDLEFIELD, CONNECTICUT.

## MACHINE FOR DRIVING SCREWS.

Specification forming part of Letters Patent No. 43,384, dated July 5, 1864.

*To all whom it may concern:*

Be it known that we, ALFRED M. BAILEY and JOHN O. COUCH, both of Middlefield, in the county of Middlesex and State of Connecticut, have invented a certain new and useful Machine or Apparatus for Driving Wood-Screws; and we hereby declare that the following is a full, clear, and exact description of the same, reference being had to the accompanying drawings, in which—

Figure 1 is a side, and Fig. 2 a sectional, elevation of the said machine.

In the construction of many articles made of wood, or partly of wood and partly of iron, external screws are used for fastening the pieces of wood, or wood and metal, together. The screws are generally penetrated into the wood by screw-drivers turned by hand, an operation slow and fatiguing, and therefore expensive.

The object of this invention is to drive wood-screws by machinery—that is to say, by means of a mechanism receiving movement from a prime mover and transmitting it to the screw-driving tool in such manner as that its work shall or may be performed with speed, accuracy, and ease; and our invention consists, first, in the production of an organized machine or apparatus or tool for driving wood-screws arranged and combined to operate as hereinafter described when actuated by a prime mover; second, in the combination with a suitable frame holding in fixed bearings the screw-driver, and with a platform to support the work to be operated upon, of a mechanism for elevating the platform to the driver, substantially in the manner and for the purposes hereinafter described; third, in the method of operating the screw-driver by a friction device, substantially as described, the same consisting of a pair of friction pads or clutches upon the tool-holder and its surrounding pulley-shaft, respectively arranged for action in conjunction with the movable platform, as described, so that by elevating the platform to the screw-driver the pads or clutches will be brought into frictional contact, whereby rotary motion may be imparted to the tool or stopped and its speed checked at pleasure.

To enable others to make and use our improved machine, we shall now proceed to describe its construction and operation.

The frame-work, which is firmly seated or

established upon a base, C, is composed of a column or standard, A, from which branch off brackets B, cast in one piece therewith, or riveted or bolted or otherwise secured thereto. The lowermost bracket supports a platform, D, through an orifice, *d*, of which passes the guide-post E, whose upper end supports the table or platform G, upon which the work to be operated upon is laid, while its lower end passes through an orifice, *d'*, in the base of the machine. A pulley, H, is hung in or to the said bracket, and a cord, *h*, fast to the guide post, passes over it and terminates at the pedal-lever I, hinged or pivoted at *e* in the rear of the standard. By this arrangement the platform G is elevated by the operator depressing with his foot the pedal *e*, the downward motion of the latter operating the cord over the pulley and raising the platform in a line determined by the two orifices *d* and *d'*, which orifices are in line with those which hold the tool. The two uppermost brackets or collars hold in their orifices a hollow shaft, K, upon which is mounted the pulley L, which receives its motion from a prime mover and transmits it to the tool in the manner hereinafter described. The hollow shaft K terminates at its lower end with or in an annular friction-pad, M, secured to the shaft by means of a set-screw, *m*. The under surface of this pad may be roughened or indented for the purpose of giving a more powerful gripe or frictional hold. Through this hollow shaft and a collar, B', in line with the other collars before referred to, passes the tool-holder N, the screw-driver being inserted in the socket in the lower end of the said holder by means of a set-screw, *n*.

To the tool-holder or spindle, and between the brackets or collars B' and B'', there is attached an annular friction-pad, M', similar to that attached to the hollow shaft, its position being reversed in relation to the other, yet corresponding, so that the indented surfaces face each other. A leather-washer, *o*, may rest on the pad M', so as to be interposed between the two indented surfaces, or some other device common to most friction clutches may be used for causing the tool-shaft and the driving-shaft to be properly coupled for operation. The descent of the tool-holder is limited by means of a stock, P, securely held in its place by means of a set-screw, *p*. Around

the screw-driver or tool proper there is a cap or block, R, the interior of which is hollow or concave, the edges being beveled inward and outwardly. Between the cap and the tool-holder there is a spiral spring, the tendency of which is to depress the cap below the under side of the screw-driver.

A machine constructed as above described is or may be operated in the manner as follows: The pieces of wood or metal which are to be united by means of screws are laid or held upon the platform G under an adjustment in such relation to the screw-driver that on raising the platform by the action of the foot on the pedal the cap R will coincide with and inclose the head of the screw. When this adjustment is effected, it will be understood that the axis of the guide-post E, the tool-holder M, and the pulley L and its shaft R are all in the same line, and that rotary motion being imparted to either part it will revolve upon an axis of revolution, which is the common axis referred to. Rotary motion being imparted to the pulley and further pressure being exerted on the pedal, the work will be crowded against the screw-driver and push it and its holder up through the hollow shaft K until its friction-pad M' comes in contact with the pad M of the pulley-shaft. From this moment the tool shaft will partake of the movement of the pulley-shaft and keep revolving so long as the pressure upon the pedal is continued. The rotary motion thus given to the screw-driver will necessarily be transmitted to the screw itself, inasmuch as the rotating edge of the driver will fall in with the nick of the screw before one revolution shall have been completed. In this way the screw is driven home with the rapidity with which the pulley itself is driven. When the screw is driven home, pressure on the pedal is released,

the platform drops, and the movement of the tool and its holder ceases simultaneously.

It will be understood that it is within the control of the operator to check or slacken the speed or power of the screw-driver by simply exerting more or less pressure upon the pedal, as before described.

Having now fully described our invention, we claim—

1. The production of an organized machine or apparatus or tool for driving wood screws, arranged and combined to operate as herein described when actuated by a prime mover.

2. The combination, with a suitable frame holding in fixed bearings the screw-driver, and with a platform to support the work to be operated upon, of a mechanism for elevating the platform to the driver, together with a self-centering screw head cap for holding the driver concentrically with the screw, substantially in the manner and for the purposes herein described.

3. The method of operating the screw-driver by a friction device, substantially as described, the same consisting of a pair of friction pads or clutches upon the tool-holder and its surrounding pulley-shaft, respectively arranged for action in conjunction with the movable platform, as described, so that by elevating the platform to the screw-driver the pads or clutches will be brought into frictional contact, whereby rotary motion may be imparted to the tool or stopped and its speed checked to pleasure.

In testimony whereof we have signed our names to this specification before two subscribing witnesses.

ALFRED M. BAILEY.

Witnesses: JOHN O. COUCH.

LYMAN A. MILLS,  
EDWIN P. AUGUR.